

iN-MOTION

Conveyors Inc.



By Roboshop Inc.

Multi Directional Capability on a Single Conveyor



iN-MOTION



**What can you do with a
Single Quiet Ride
Conveyor?**

**More than you
thought Possible !**

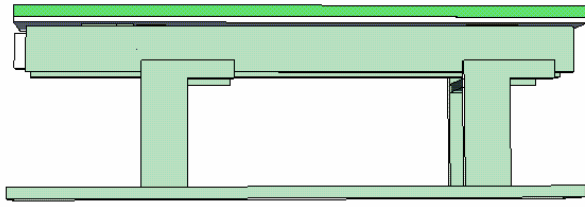

Flat Bed

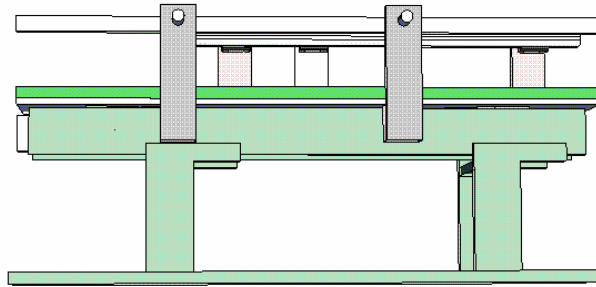

With Guide Rails

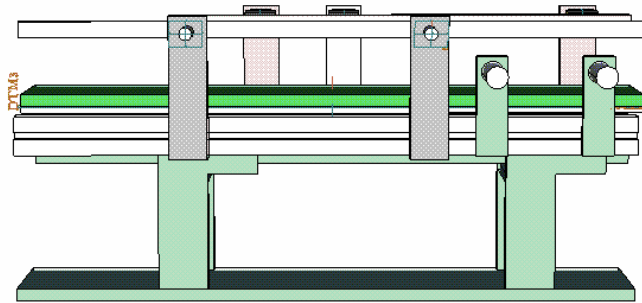

Guide Rails and OEM Support Rail

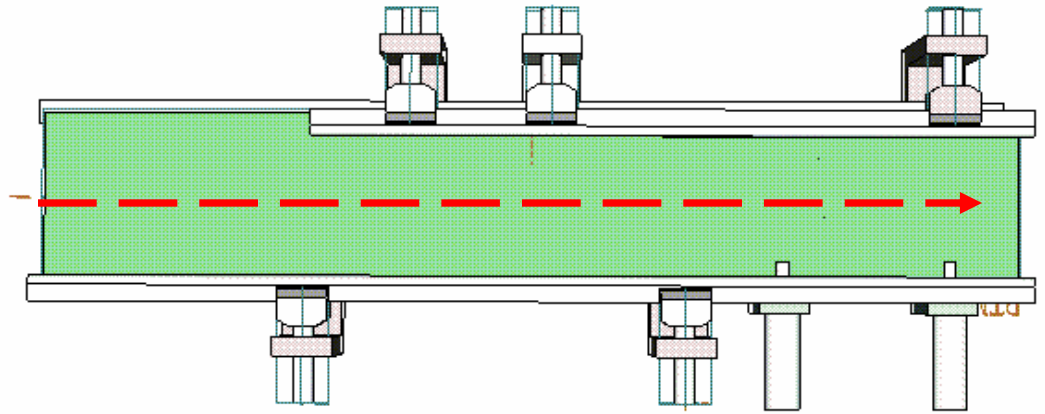

Single direction part flow

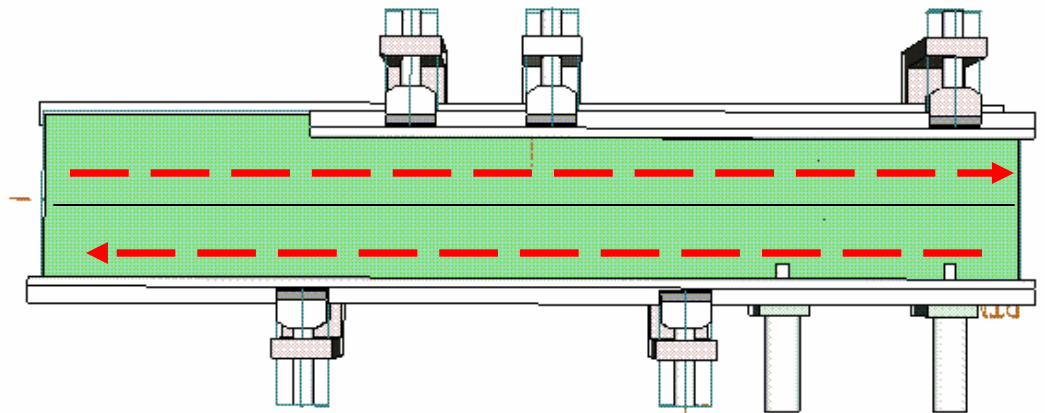

Dual direction part flow

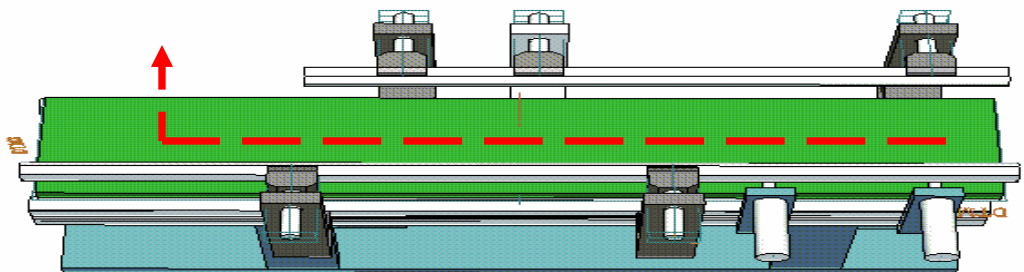

Single direction part flow with 90° Turn

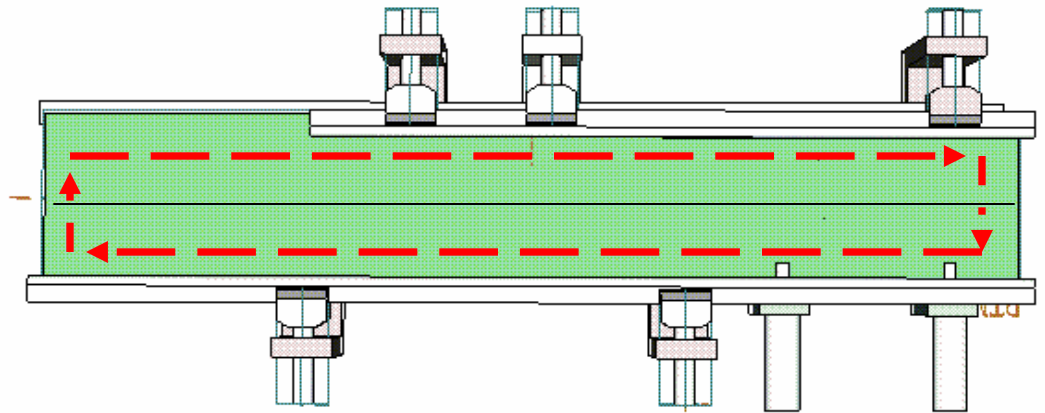

4 Direction part flow with 180 ° Turns

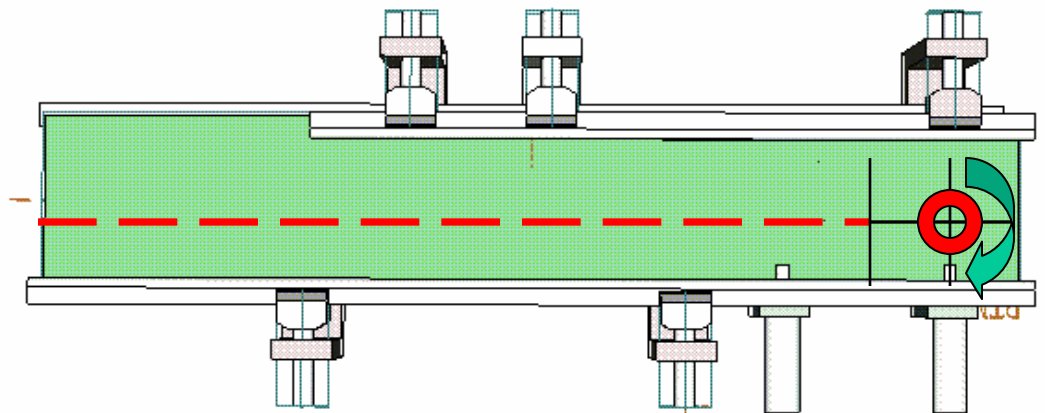

Single direction part flow with orientation

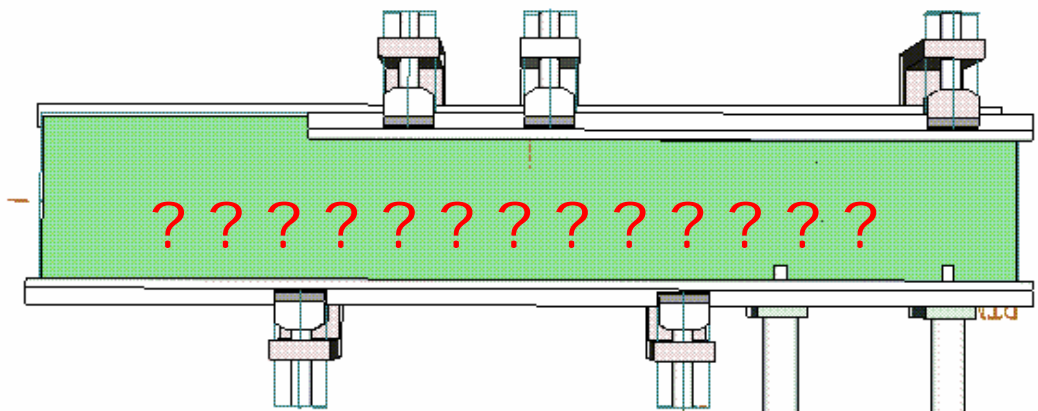

iN-MOTION



**Now just think
what you could do
with TWO**



Dual side in, single part flow out

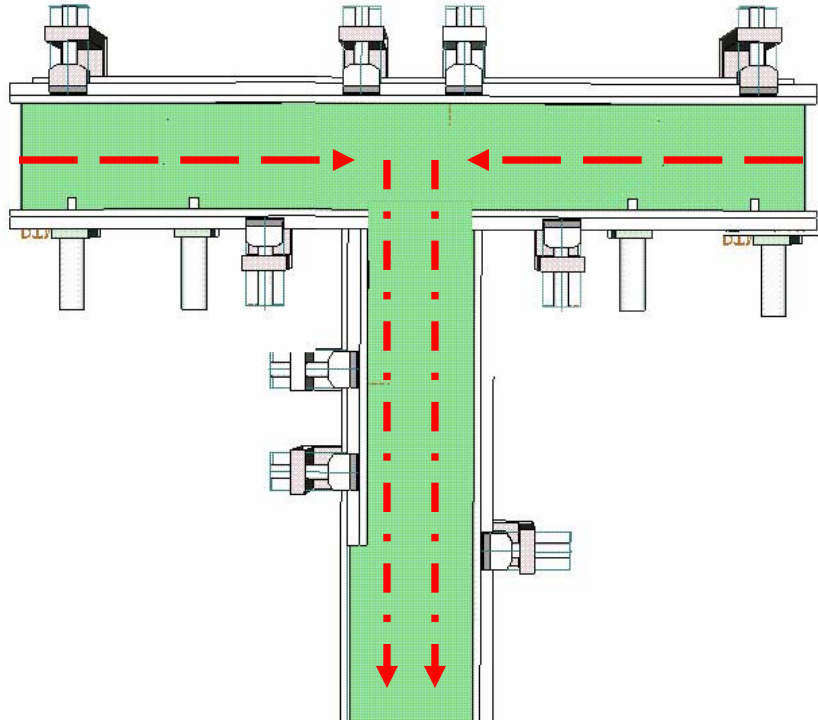

Part in, - 180 ° part travel - part out

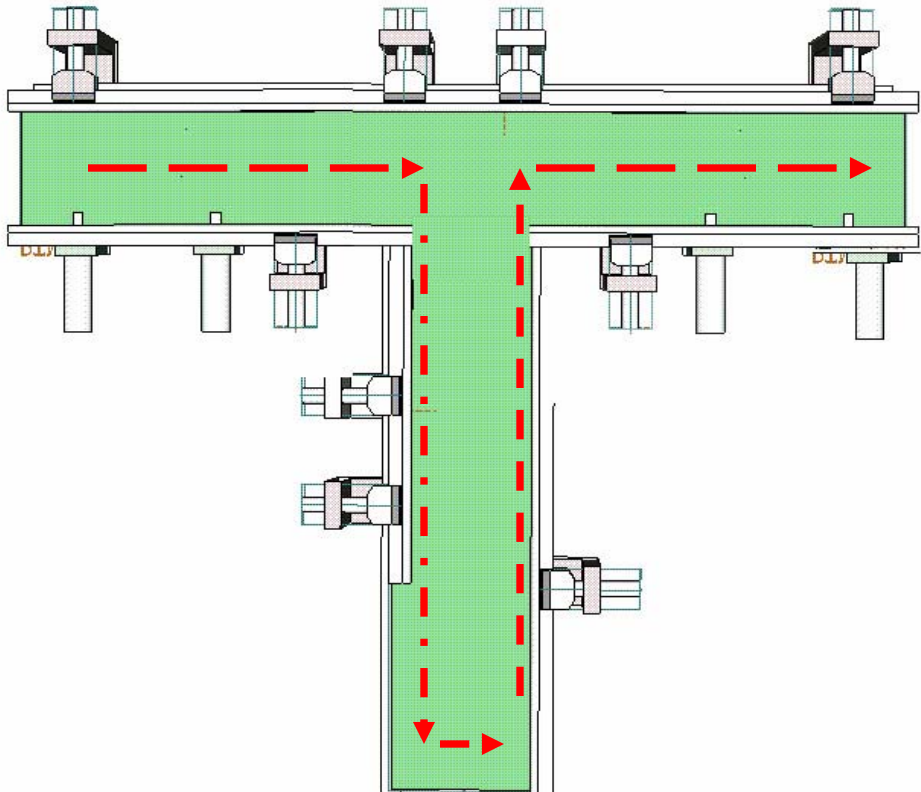

iN-MOTION

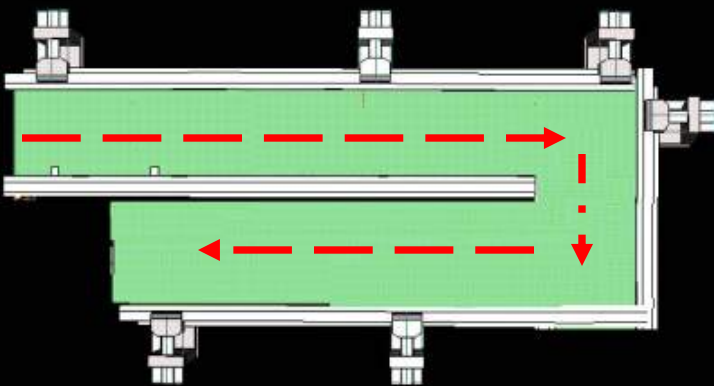
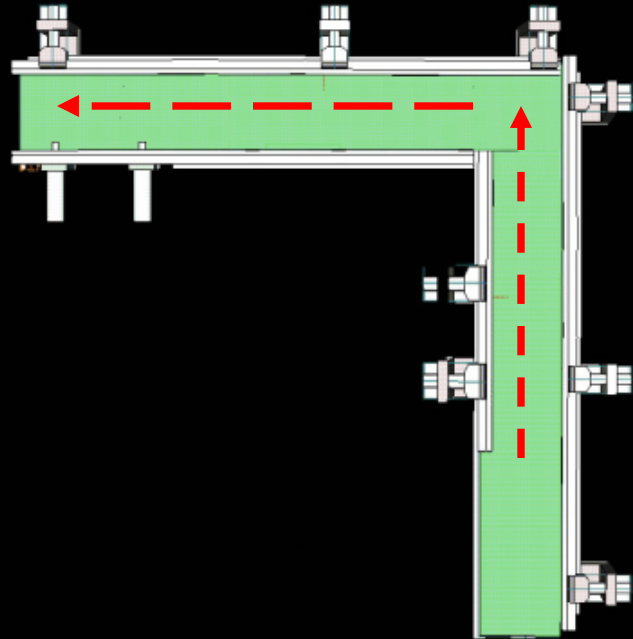
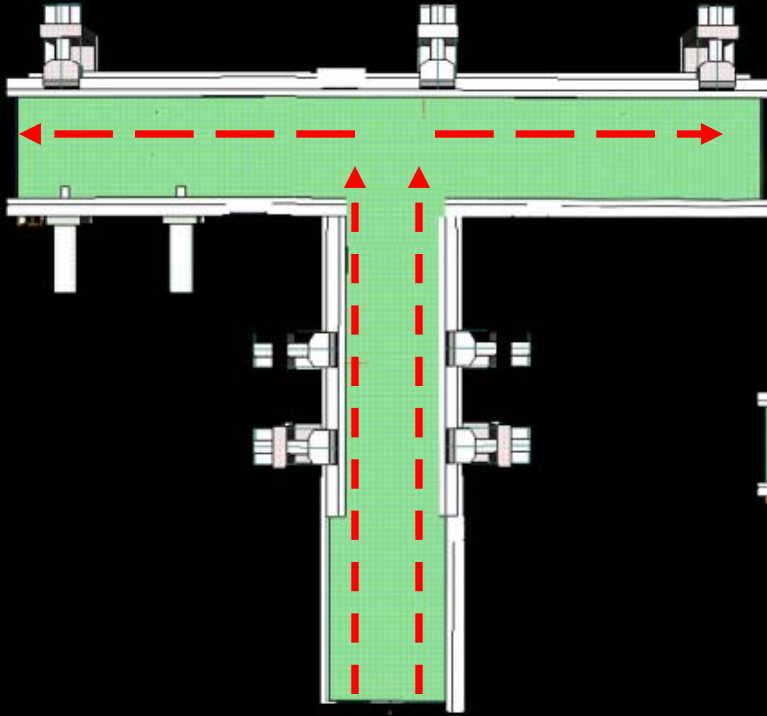

iN-MOTION

Belt Conveyors

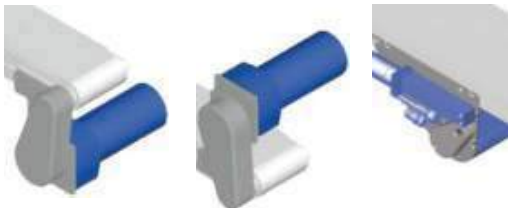

Quiet Ride Series



**Very Minimal
movement (.040")**

**No Pulleys
No Pinch Points**

**No Tracking
Adjustments or
Problems**

**No Drives to get
in the Way**

Belt Change

Belt Conveyors



**Remove conveyor
from stand**



Remove Drive and Motor

Remove side rail



Loosen belt Tension



**Remove Belt and
Replace**



Adjust Tracking



Begin Reassembling

Brush Change

Quiet Ride Series

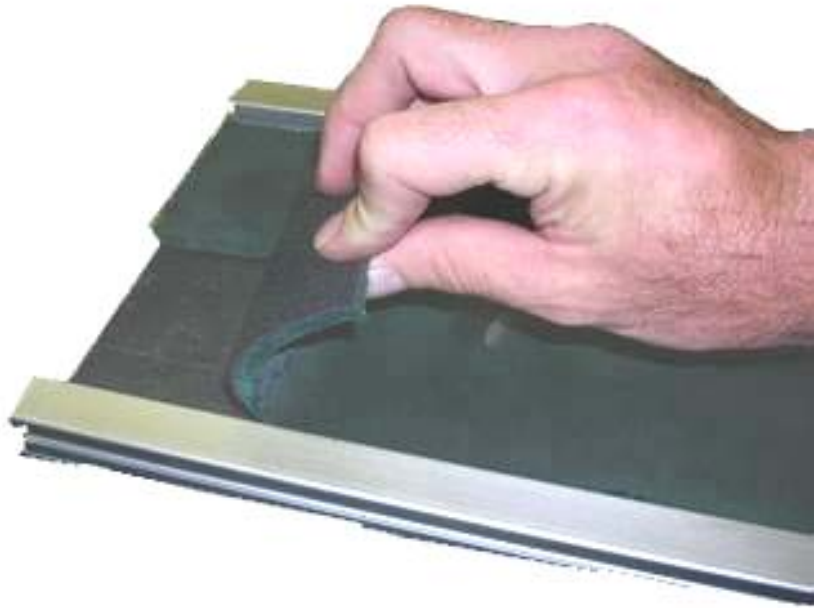

**Peel it back, and Pull it off the Hook and Loop,
Then Press it Back on.**

**That is all it Takes to Change Over our
conveyor while it is still in place**

ADVANTAGE QUIET RIDE SERIES

iN-MOTION

Safety

Belt Conveyors

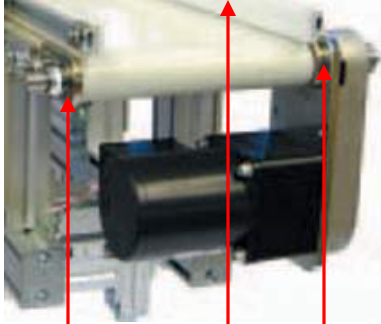

Multiple Pinch Points

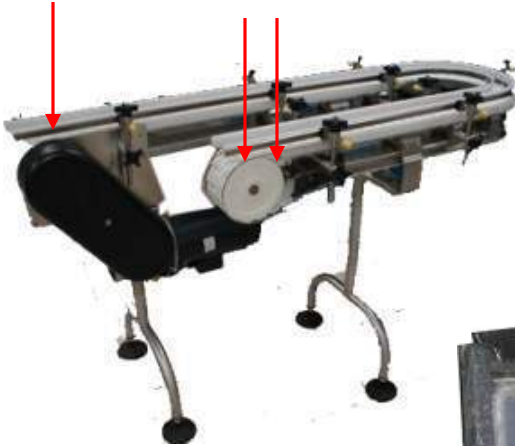

Quiet Ride Series



Only .040" of movement



No Pinch Points –The Industries Safest Conveyor`

ADVANTAGE QUIET RIDE SERIES

Quiet Ride Advantages

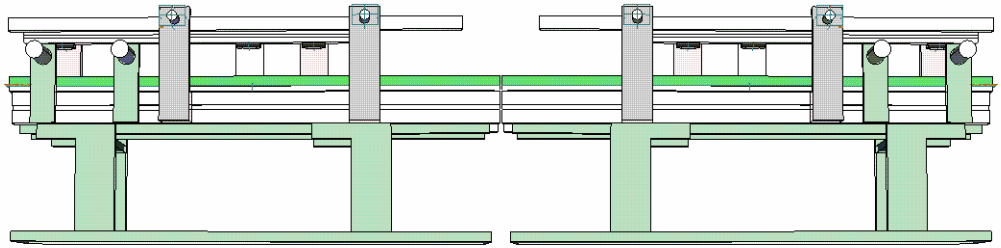

Easy to interconnect multiple conveyors for longer length applications, set end to end and parts easily transfer from one conveyor to the next.



No Special radius nose that reduce belt life is required

compensation for part bounce as conveyor radius meet



Quiet Ride Advantages



**Any Change in Direction
will Dramatically
increase your savings
with our
Quiet Ride Conveyors**

iN-MOTION

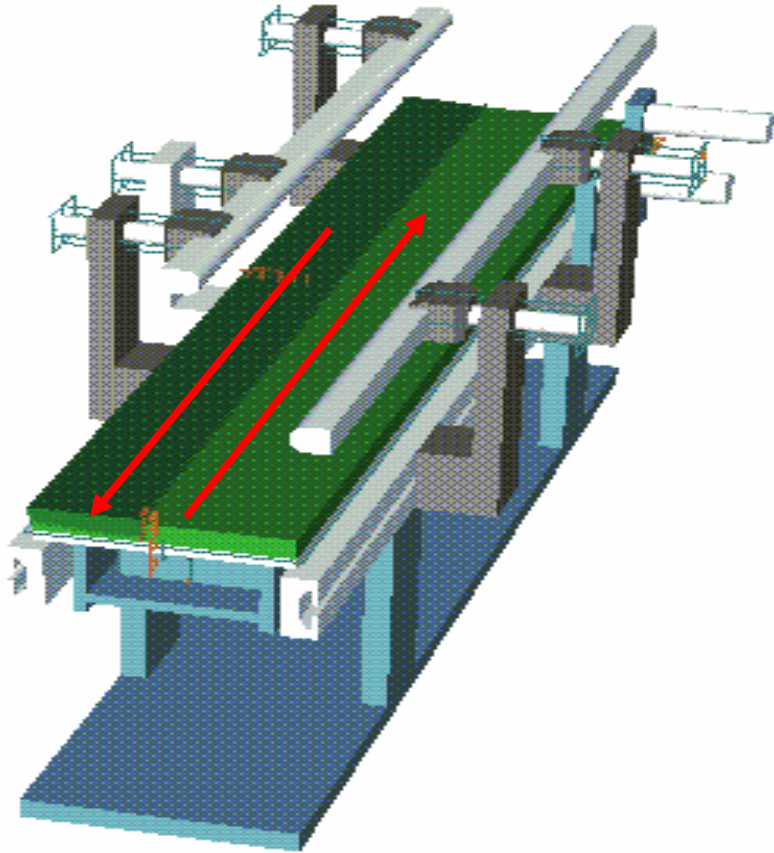

No need to buy expensive attachments or buy 2 conveyors, Split the brush and turn one section in opposite direction

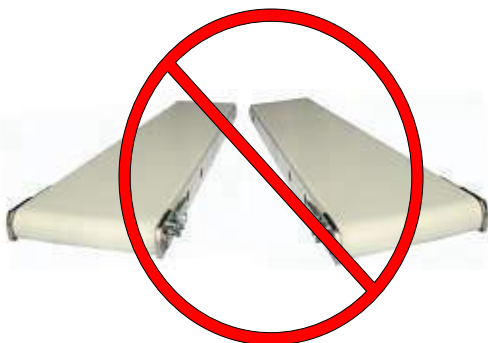

iN-MOTION

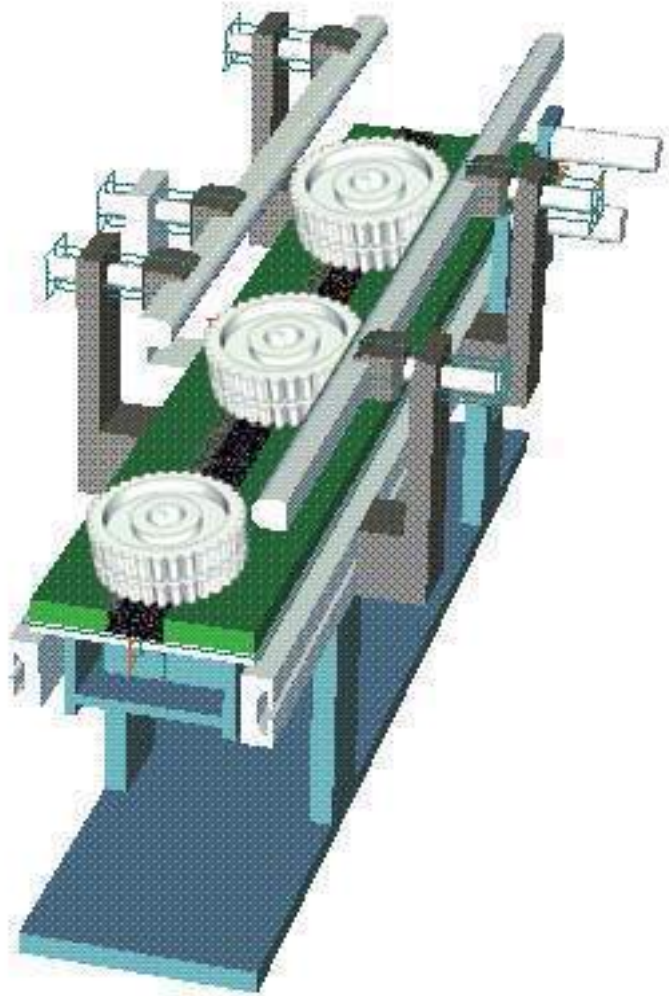

**For Wider Parts, and for Oils, Coolants,
and Water drainage Split Brush in to
segments is An excellent cost saving
solution**

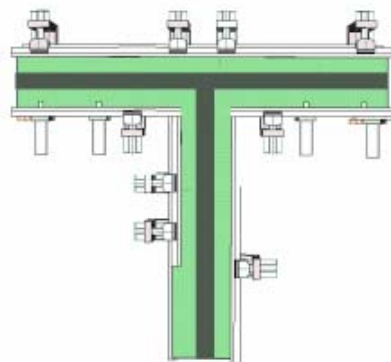
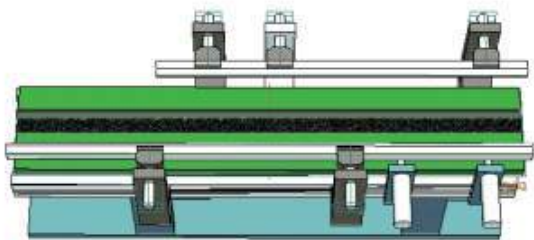

Vibratory Conveyors - There is a Difference!

Ours

Theirs



**If you have had Experience with
Vibratory Conveyors before**

Forget what you Learned



We took the Bounce out of Vibratory Conveyors

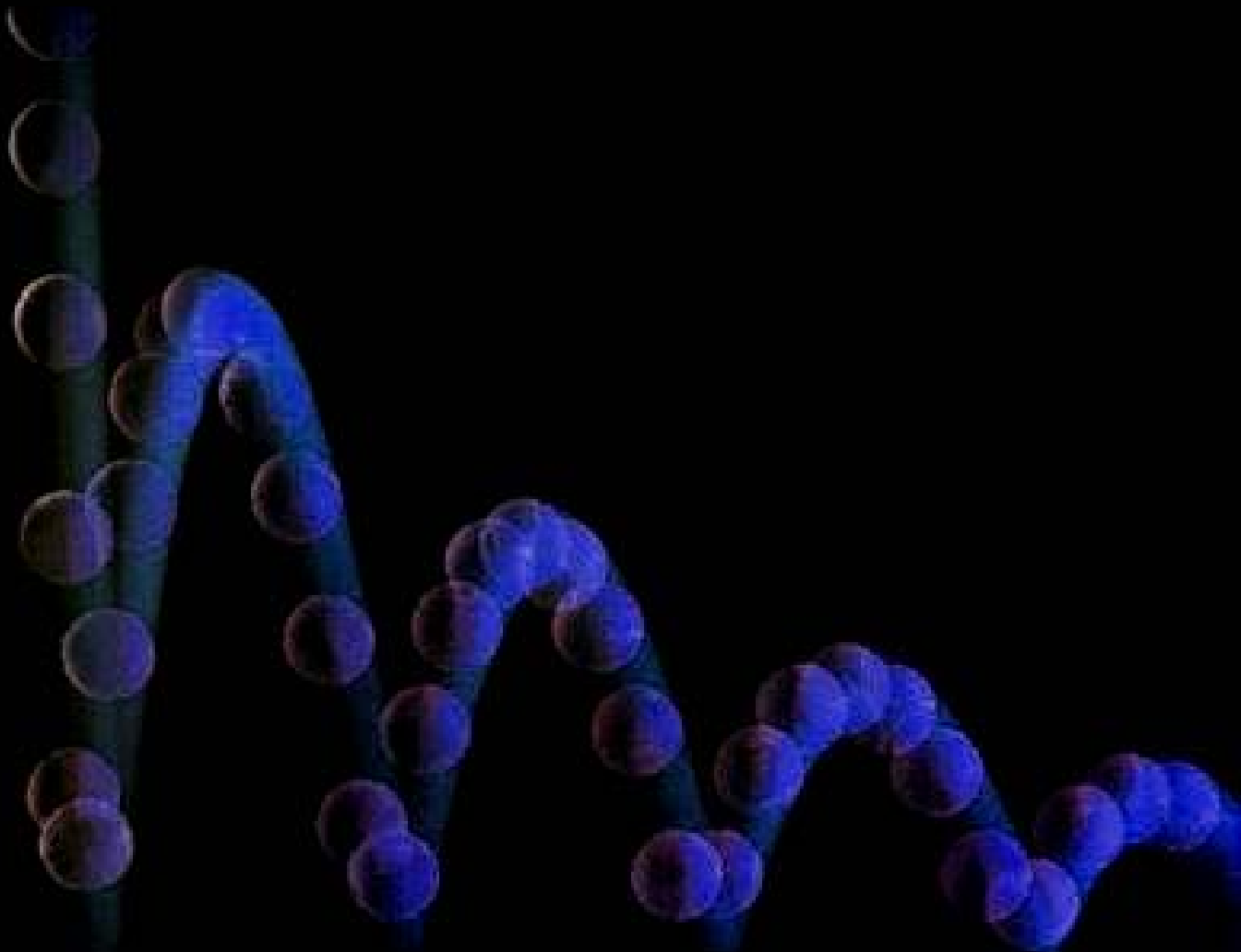

Other Vibratory Conveyors

Low Profile ???

Other Vibratory Conveyor Manufacturers

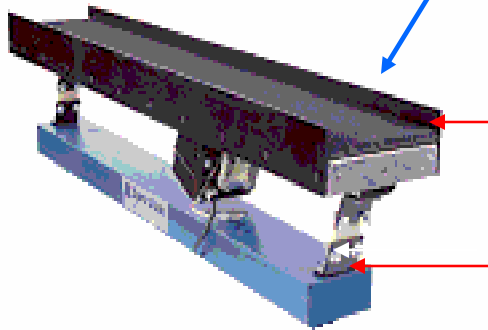

11.5"



12-17" High



8-9" High

Quiet Ride Series



3" High Standard Height

Vibratory Conveyors

How Other Vibratory Conveyors Work

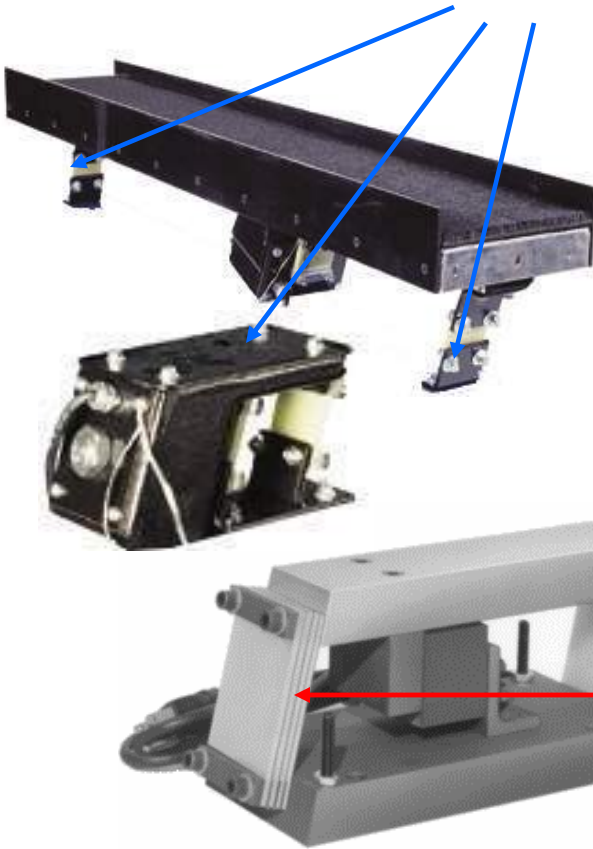

Large Heavy Coils, with spring packs set at angles, mechanically adjusted adding spring packs to find resonance, Complicated adjusting to make conveyor bed properly resonate.

By Adding Springs you adjust for part weight size , resonance, etc. Spring packs need retuning and replacing.

Throws parts up and forward to move

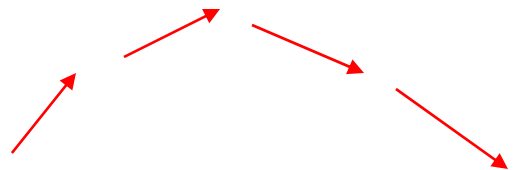
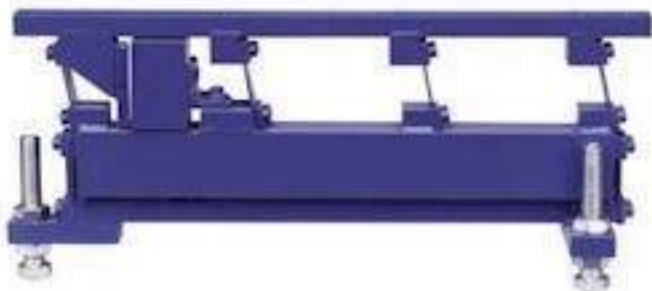



Vibratory Conveyors

How Other Vibratory Conveyors Work



Unlike The Quiet Ride series To get parts to travel in 2 directions . Others manufacturers must use 2 sets of coils and spring packs set opposite directions. They are not 180° dual directional in a single unit



Sometimes difficult to resonate properly, large bulky units must be used along with heavy stands to stabilize unit and help keep unit in resonance

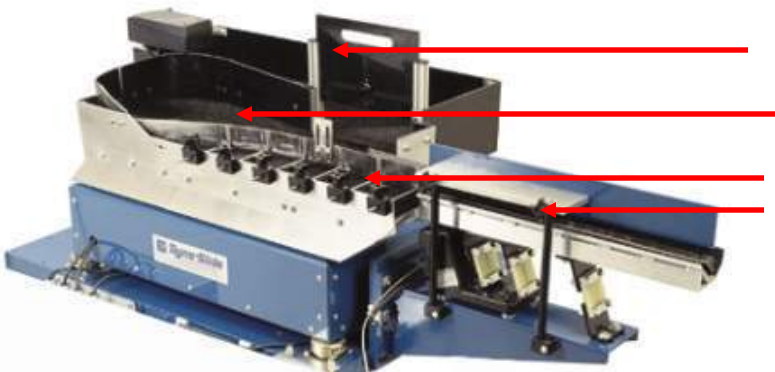

Multiple Unit feeders have cross interference issues With vibration transfer effecting next units performance

Other Vibratory Conveyors

Why can't They go in both directions?

On competitors vibratory feeder, material is “thrown” up and forward so that it drops to the surface at a point further down the tray.

This is the feeder's amplitude.

The number of times per minute that this repeats is the frequency.

A third variable is the angle of deflection... meaning how high the product is thrown as compared to its horizontal movement.

The brush surface acts like a spring enhancing the forward movement

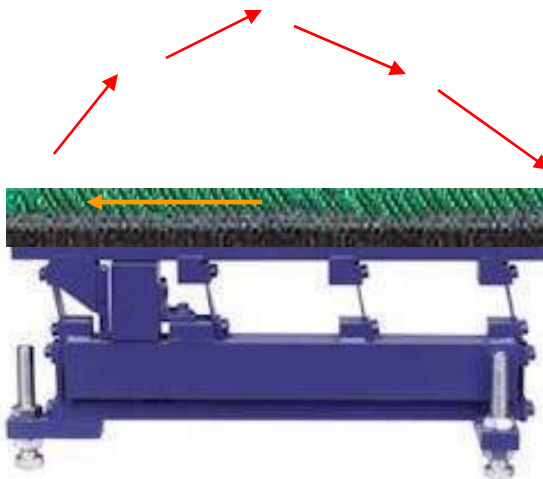
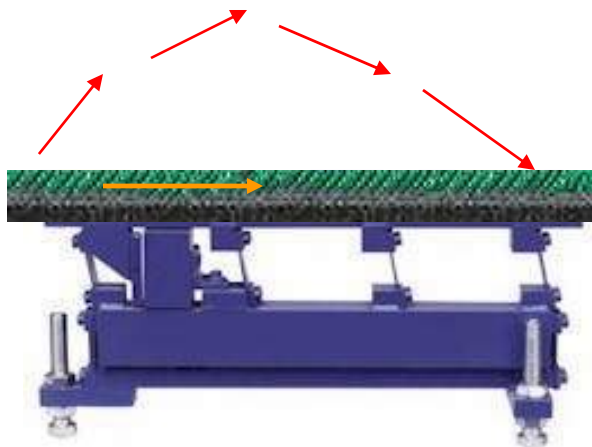

By reversing The Brush Bias you are forcing the Amplitude against the bias of the brush making the brush act as a “friction stop”. The part cannot move forward and just bounces uncontrolled.

iN-MOTION



Other Vibratory Conveyors

In applications does it matter

Yes if back pressure is somewhat High the parts can climb with the traditional Vibrator conveying movement and damage each other.

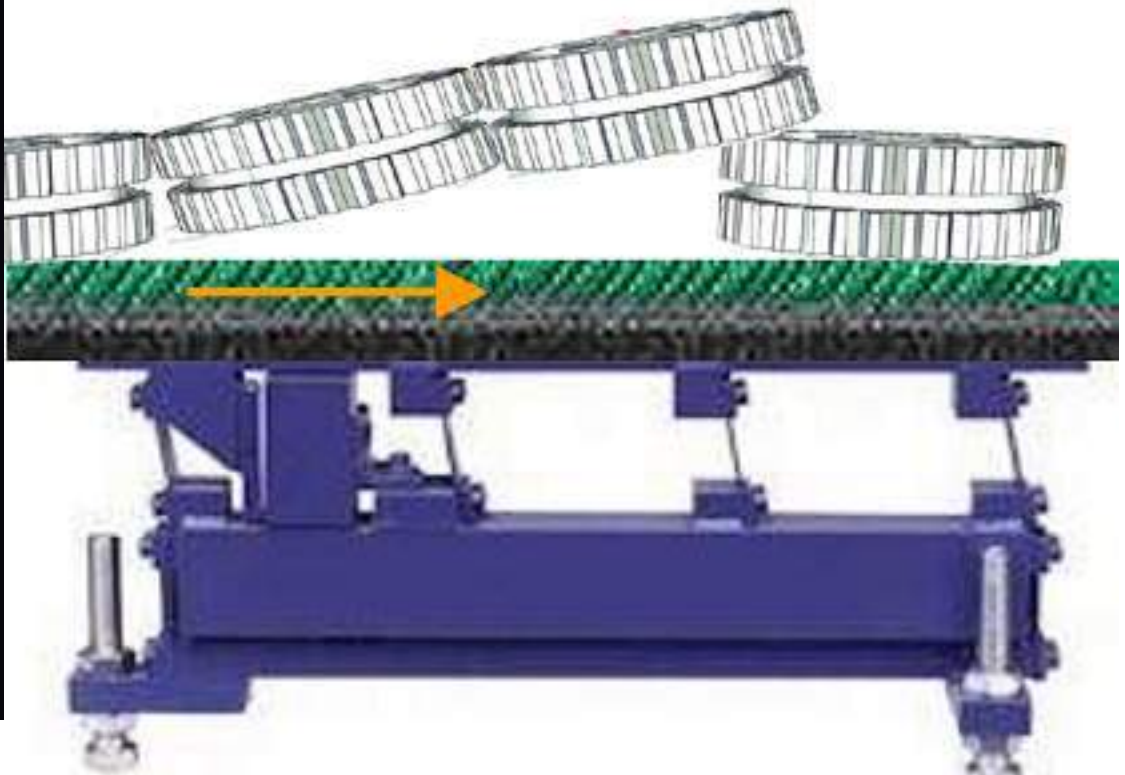

With Quiet Ride No Bounce means no Climbing action takes place



iN-MOTION



Vibratory Conveyors

So To Accomplish This on One conveyor



You will have to have
two of these



The More Directions Changed the More Competitors units
you will need to match 1 Quiet Ride System Conveyor



Accumulation Conveyors Made Easy

How easy is it to set up with the Quiet Ride System

**Start with a Table Size you need .
Then determine how wide your
lanes should be to fit your part.
Then how many " Buffer lanes"
you require for your part.**

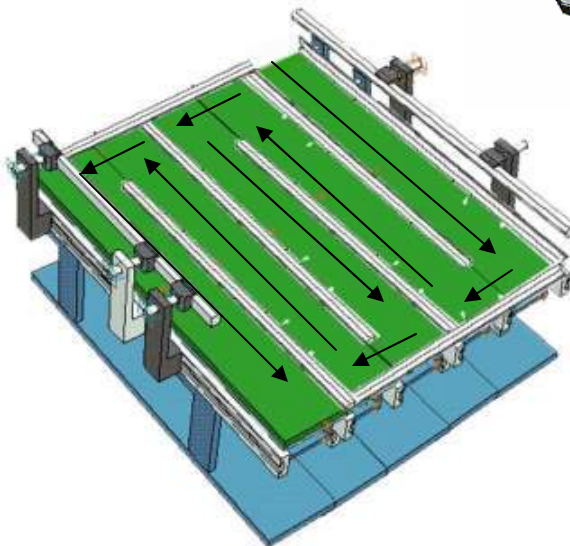
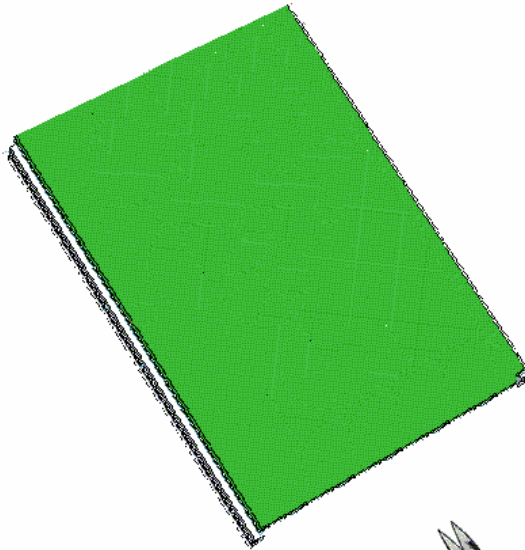

**Start Cutting
your Brush into
these widths**

**Place the brush
bias in the
direction you
want the part to
travel, add side
rails if desired
and your done.**

**It is that easy, no additional drives, motors coils belts
pulleys to add.**

iN-MOTION

Conveyors Inc.



By Roboshop Inc.